

2010

The Marshall Differential Analyzer: a Visual Interpretation of Mathematics

Bonita A. Lawrence

Richard P. Merritt

Devon A. Tivener

Follow this and additional works at: http://ecommons.udayton.edu/mth_epumd



Part of the [Mathematics Commons](#)

eCommons Citation

Lawrence, Bonita A.; Merritt, Richard P.; and Tivener, Devon A., "The Marshall Differential Analyzer: a Visual Interpretation of Mathematics" (2010). *Undergraduate Mathematics Day, Electronic Proceedings*. Paper 28.
http://ecommons.udayton.edu/mth_epumd/28

This Article is brought to you for free and open access by the Department of Mathematics at eCommons. It has been accepted for inclusion in Undergraduate Mathematics Day, Electronic Proceedings by an authorized administrator of eCommons. For more information, please contact frice1@udayton.edu, mschlangen1@udayton.edu.

THE MARSHALL DIFFERENTIAL ANALYZER: A VISUAL INTERPRETATION OF MATHEMATICS

Bonita A. Lawrence, Richard P. Merritt and Devon A. Tivener

Marshall University
Department of Mathematics
Huntington, WV 25702 USA
e-mail: lawrence@marshall.edu,
merritt37@marshall.edu, tivener1@marshall.edu

Abstract

Mechanical integration is an idea dating back to the late 1800's discovered by James Thomson, brother of Lord Kelvin. This idea was then expanded to build a calculating machine, called a differential analyzer, by Vannevar Bush (M.I.T) in 1929. The Marshall University Differential Analyzer Team has followed in the footsteps of Dr. Bush and a gentleman named Dr. Arthur Porter, who was the first to build a differential analyzer in England when he was a student of Dr. Douglas Hartree. He built his machine of Meccano components, the British version of Erector Set. In the early days of Arthur Porter's research, the machine was used to solve ordinary differential equations and the results were compared to those of more sophisticated differential analyzers of that time. Dr. Porter's research proved that the Meccano differential analyzer was well suited for many dynamical systems applications. The Team has recently constructed the only two publicly accessible differential analyzers in the USA, a mini two integrator machine and a larger four integrator machine built in the spirit of the Porter Meccano Manchester Differential Analyzer. They are continuing in the spirit of Dr. Porter's work. In this work we will give a brief overview of the Marshall Differential Analyzer Project, the mechanics of the machine and the mathematics that can be described by the mechanics. An example will be presented to unify the mechanics and the mathematical concepts.

1 Introduction

This idea of using mechanical interrelationships to solve differential equations was a compilation of several different works all organized by one man named Vannevar Bush. In the late 1800's a machine was built to solve linear differential equations of any order. Its inventor, James Thomson, discovered the disk and globe relationship, which uses successive approximations to evaluate an integral. However, the scientists of the time could not overcome the complication of torque amplification. So using the machine for non-linear purposes was an unrealized concept.

Bush envisioned a new machine that would go well beyond the scope of the former. With the help of several machinists, he designed the torque amplifier. The torque amplifier worked like a capstan pulley and would bypass the problem by tracking the motion of the wheel then transferring that same motion to the rest of the machine. Since torque was no longer an issue, the applications that could be modeled on the differential analyzer by differential equations were useful issues such as making ballistic tables for bouncing bombs, and gun-fire control, as well as applications in electrical engineering.

Unfortunately, the differential analyzer was replaced by modern computers and fell out of the history book. It has been our task for the past several years to revive the differential analyzer and continue Bush's work. Along our journey we have found that using the differential analyzer provides an elegant visual interpretation of an equation as well as many other mathematical concepts. Our goal from the beginning has been to provide students and teachers alike with an alternative perception of abstract mathematics using the differential analyzer. In particular, we have compared the theory of integration with mechanical integration by using the Riemann sum.

2 The Components of the Machine

The Differential Analyzer is an analogue computer designed to solve ordinary differential equations. The construction of such a machine includes four major components. The first of these components is the integrator, which will be discussed in great detail later in this work. This component is the most important because integration is the primary mechanical operation for solving differential equations with the differential analyzer.

Basically the integrator consists of rotating disk, a wheel, and a lead screw. The disk is mounted on a carriage so that it is allowed to move in a strictly linear manner. Additionally, while the disk is being turned, this motion moves the wheel. Now, the rotation of the lead screw moves the carriage, so that the set up is essentially a continuously variable gear ratio.

The next component is the torque amplifier; this allows the motion of the wheel to be transferred to the connecting parts of the machine. The need for the torque amplifier is strictly for mechanical purposes; since the force of friction from the disk to the wheel is considerably small, the output of the wheel doesn't have enough torque to turn the moving parts of the machine.

The last two components of the machine, the input and output tables, are very similar in design. The former allows us to translate a graph in normal Cartesian coordinates in terms of shaft rotations and feed the motion into the machine. The latter will draw a plot of the solution against time or any other motion created by the machine representing terms of the associated differential equation. These two components will also be discussed in more detail later.

3 The Mechanics of Integration

To understand specifically how the differential analyzer integrates, one must first know precisely what the machine is doing mechanically. As previously mentioned the integrator unit consists of three main components, the disk, wheel, and the lead screw. Mathematically, the motion of these components represent the independent variable, the integral, and the integrand, respectively. It is important to note that the motion of the wheel is strictly one-dimensional, that is, the wheel picks up successive arcs of some fixed concentric circle on the disk. This is due to the fact that the wheel is fixed and cannot move in a linear direction by design. The only movement picked up by the wheel is along an arc of a circle. The disk however, is allowed to turn as well as move in a linear direction. This is possible by means of a spline shaft, or key-way rod.

Now, integration takes place because the wheel adds up all differences in gear-ratios the very instant they are created. These gear ratios are now called the derivative. So the derivative is essentially the rotation of the lead screw. Also note here that the derivative is the function to be integrated. The rotation of the wheel depends on the rotation of the disk. With dependence on the distance from the center of the disk to the edge of the wheel, the number of turns of the wheel is dependent on the number of turns of the disk. This is because the derivative is defined to be some change in distance which is essentially a change in gear ratio.

Consider the following cases:

Case 1:

Suppose the derivative distance is initially set one inch from center, and remains constant. Additionally, assume that the radius of the wheel is measured to be one inch. Therefore, if the disk turns n times, then the wheel turns n times as well. This tells us that if the derivative distance equals the radius of the wheel, then the wheel:disk ratio is one-to-one.

Case 2: Let's suppose the derivative distance is set to two inches instead, and everything else is as in Case 1. So, if the disk turns once, then the wheel turns twice. We see that the disk:wheel ratio is 1:2 in this case.

Case 3: Finally, let's assume the same initial derivative distance as in Case 2 but we want to now rotate the disk through a portion of a turn. Since one turn equals 2π radians, if the disk turns one-half turn it turns through π radians. So if the disk turns π radians then the wheel will turn half as much as in Case 2, which is once. Note that the disk:wheel ratio is still 1:2.

Now we can see that the rotation of wheel depends on the derivative distance and the number of turns of the disk. Note that the derivative distance is defined to be the distance from the center of the disk to the edge of the wheel. So, if the wheel position is fixed through some portion of a turn of the disk, the wheel is turned that portion of turn multiplied by the disk:wheel ratio.

For convenience, let r denote the derivative distance, s denote the output of the wheel, and $\Delta\theta$ denote some portion of a turn of the disk. The next question is "What's

the disk:wheel ratio?”. The wheel acts like a gear. However, since the wheel does not have gear teeth, the radius of the wheel is used to find the ratio, similar to the calculation for a pulley. If we let the radius of the wheel be denoted by a , we have disk:wheel ratio = $r:a$ ratio. Now we gather that the wheel output $s = (r/a) * \Delta\theta$. Since a is constant $s = (1/a) * r * \Delta\theta$.

In other words, the output of the wheel is represented by an arc length with respect to some prescribed concentric circle on the disk. This is how the machine integrates a constant function $r = f(\theta)$, where the derivative distance r remains constant. For example, suppose $r = a$, so that the disk:wheel ratio is 1. As mentioned previously, the disk is the independent variable, so for $\theta = 1, 2, 3, \dots$, $s = 1, 2, 3, \dots$, respectively. Denoting θ as the independent variable and s as the dependent variable, a Cartesian plot of these values will be the line $s = \theta$.

As another example, suppose $r = 2a$ then a Cartesian plot of these values is also a line $s = 2\theta$ etc.. With respect to the plot, the rate of change is constant and so the function is linear, and with respect to the integrator on the differential analyzer, the derivative distance is constant so the output is linear. This is the correlation between the machine and the mathematics. In this particular linear case this linear function is precisely the integral value of the constant function evaluated over some real interval. Of course this idea can be extended to the piecewise continuous case as follows. (See Figure 1.)

Here we are given three discrete values for r . For each value, the wheel is displaced by the carriage at some fixed distance r_n . The disk is then rotated through some portion of a turn $\Delta\theta$. At the start of each portion of a turn the disk rotation is stopped and the carriage is displaced to provide a new derivative distance r . Hence, each time this is done the wheel picks up an arc length proportional to the rotation of the disk. Continuing in this manner for some n finite trials, with each trial having an arc length defined by $s_i = r_i\Delta\theta_i, i = 1, 2, \dots, n$, the total arc length for all these piecewise continuous arcs is defined by

$$\sum_i^n r_i\Delta\theta_i; \tag{1}$$

taking into account our changing gear ratios, the number of turns of the output is defined by

$$(1/a) * \sum_i^n r_i\Delta\theta_i. \tag{2}$$

At this point we are only considering functions that are piecewise continuous, and more specifically, only piecewise constant functions. As a result the integral is a piecewise linear function. However, we are interested in finding integrals of all functions that can be described by turns of the lead screw and the disk. As a point of fact, the

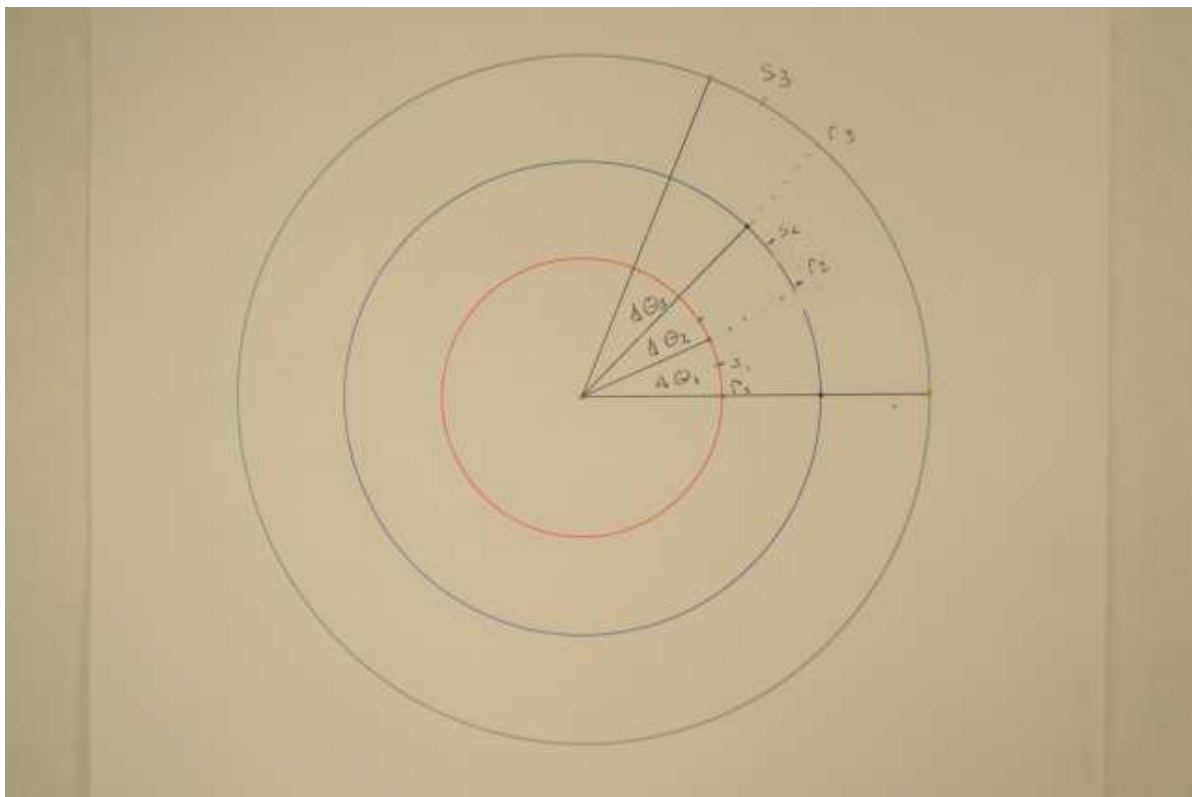

Figure 1: The Discrete Case

summation of arc lengths is a Riemann sum and the general rule of finding the integral of any function is the same as finding them for a constant function.

For example, suppose the derivative distance is now linear, that is, has a constant rate of change. This can be achieved by taking the output from one trial of the discrete case and letting it drive the derivative distance for another integrator. So in a mechanical sense, the gear ratios are always changing by some constant factor. What the differential analyzer does to deal with this constant change, is partition the interval, and then take refinements of it. Imagine the three discrete cases from figure 1 as being very small increments of a portion of a turn. (See Figure 2.)

In this case the derivative distance moves in a continuous manner so that the consecutive arc lengths are very small. The arcs can be a portion of any of the infinite number of concentric circles that can be represented on the disk. If the derivative distance is changed by any amount then the wheel will always rest on a unique concentric circle. This provides us with a definition of the integral since we know the definition for a given arc length defined for a unique circle. The definition, as mentioned in the former cases for n finite trials, will become an integral as each refinement of a partition of $\Delta\theta$ becomes further refined.

In other words the independent variable interval becomes more refined as the deriva-

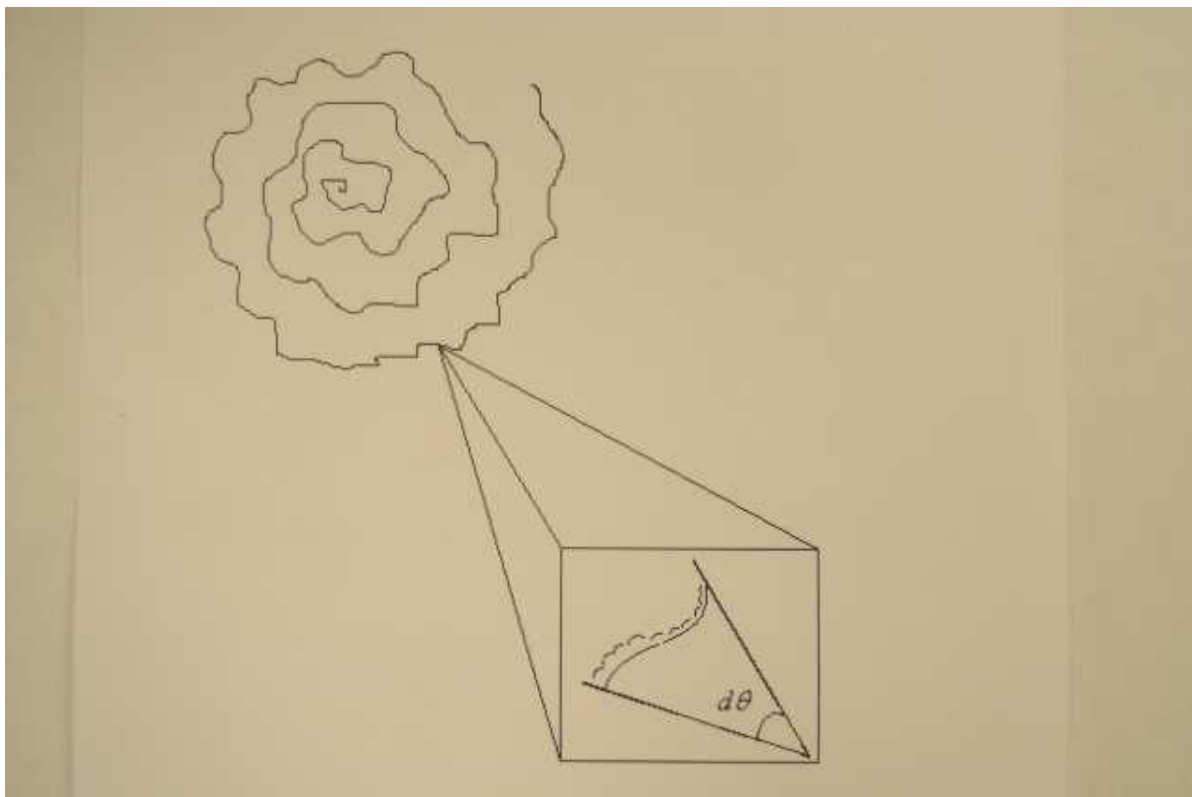

Figure 2: The Zoomed in View

tive distance changes continuously. These refinements of some partitions of an interval are what is needed to define an integral. The big question now is “how does the differential analyzer refine a partition?” It does so by design. Remember that the wheel always makes contact with the disk, and the wheel always rests on some arbitrary concentric circle, so at any instant in time (which is defined on the machine as the turning of the disk) the wheel picks up an arc length. As long as the angular velocity of the lead screw does not exceed that of the disk, the wheel will instantaneously add up all rates of change in the form of arc lengths.

In order to be mathematically precise, the thickness of the wheel’s edge must be defined as the limit of all refinements of a partition, so that the integral is not just an approximation of the theoretical value. However, realistically when working with the differential analyzer, all results are relative to some predetermined value. One can assume that the thickness of the wheel’s edge is of negligible value. In this case suppose the wheel’s edge is very thin. In fact make it as sharp as a razor blade. Then define one unit as an inch in linear distance. The comparison of one inch to the thickness of a razor blade will provide a very considerable range from one unit to the next. Moreover, a measured value is only as accurate as the tool we use to measure it, the tool in this case being the wheel. So if we assume that the thickness of wheel is infinitely small

then the theoretical value is achieved, as a mathematician would expect.

4 Solving Differential Equations

Now that we know how the machine integrates, we can focus on using the machine to solve differential equations. The method of solving differential equations with the differential analyzer is a term-wise process. The operator starts with the highest order derivative and reduces the order by one by passing the motion through an integrator. This process is repeated until the dependent variable is obtained. This is done by connecting the output of one integrator to the input (derivative distance drive/leadscrew) of another integrator. The number of times this process should be repeated depends on the order of the equation. Thus the higher the order of the equation, the higher the number of integrators required. The set-up is comparable to that of the programming of a computer. When the motion representing the dependent variable (the solution) is obtained, the connection back to the highest order derivative must be made (closing the circuit) according to the differential equation.

In many cases, the differential equation may contain several terms. In such a case, all terms must be added with the use of a differential gear (adder). Sometimes, an operator may use several adder units to add up all the terms of the equation. The last step (closing the circuit) is perhaps the most important. The differential equation must be put in the form such that the highest order derivative is the only term on one side of the equation to determine how the final connection must be made. That is, the input shaft of the integrator with the highest order derivative must be connected to a shaft that represents the other side of the differential equation.

Consider the D.E. $\ddot{y} = -y$, or, in other words the statement that acceleration is always equivalent to the negative of position of a moving object. We need a synthetic view of the procedure and a general rule for the programming of the machine. Thanks to Bush the founder of the D.A., we can draw a schematic diagram of the connections. (See Figure 3.)

The rectangular space(s) at the top of the diagram represent integrator(s), and the lines beneath them represent an avenue of connections (bus shafts) that connect the integrators together. The interconnections of the integrators are what describe a particular differential equation. There are three very important facts of notations involved when drawing a schematic for the D.A. Looking at an integrator, the vertical shaft furthest to the right will always represent the independent variable. Note that this is not necessarily time. The vertical shaft coming off the wheel is the integral and the third shaft represents the derivative distance.

Although, the movement of all components takes place at any moment in time, one can follow the path of motion by starting (in this case) with the second derivative. Beginning with \ddot{y} , we label the input of the first integrator as this second derivative. Following that motion through the output of the first integrator, it then becomes the first derivative. That motion leads to the input of the second integrator and through

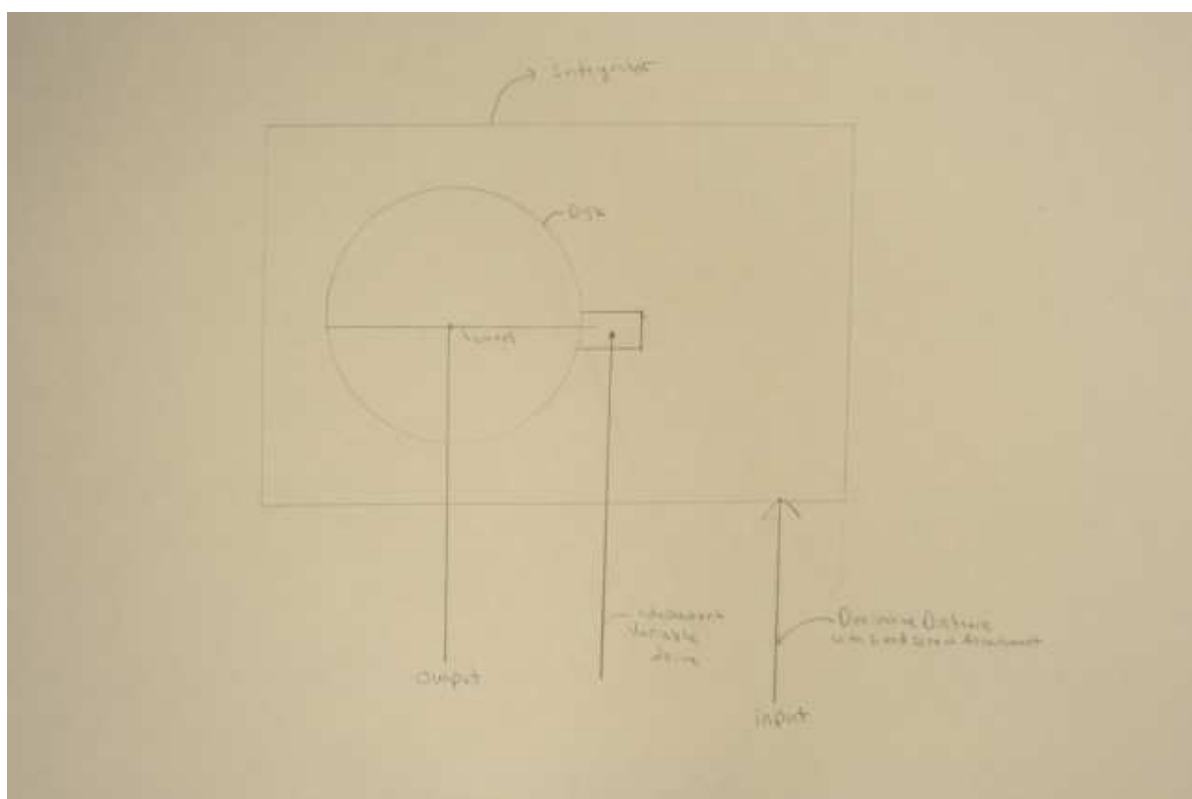
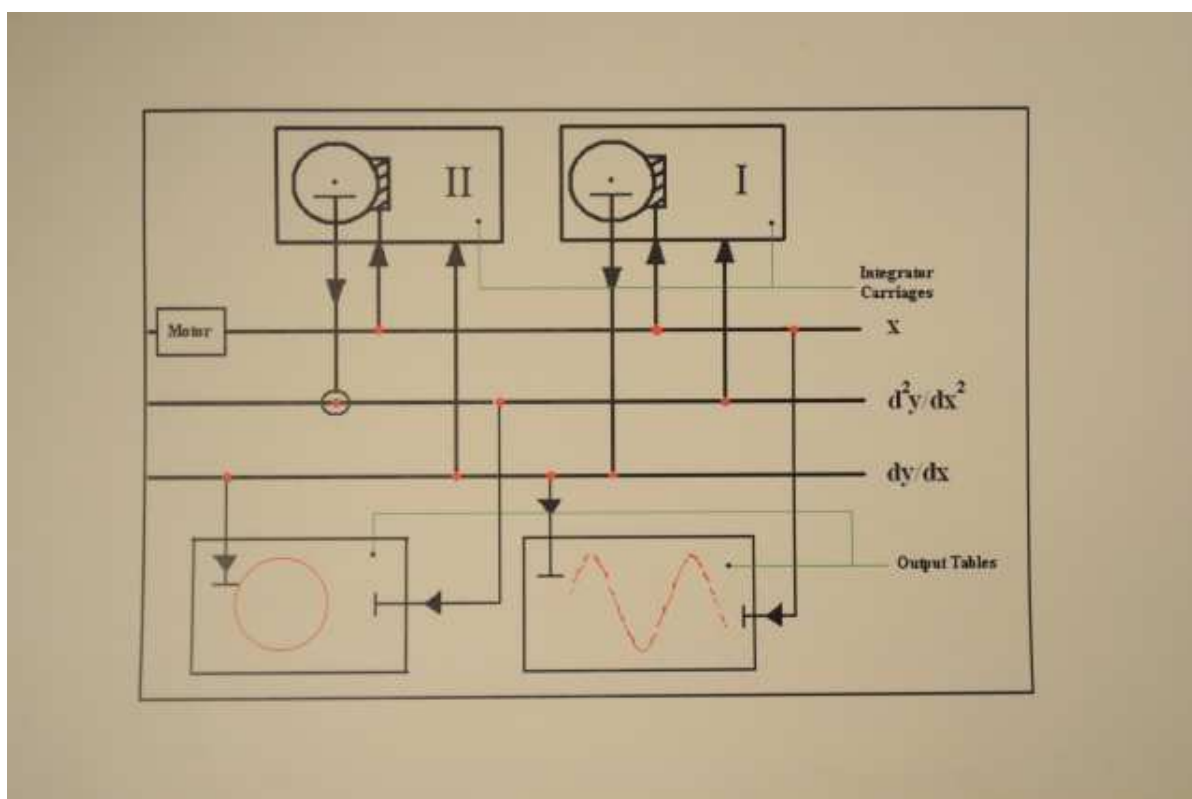

Figure 3: The Bush Schematic of an Integrator

the output of the second integrator. At this point it becomes the dependent variable y . Notice the round highlighted circle around the connection from the output of the second integrator to the connecting bus shaft. A dot represents a connection and this red circle represents a sign change. In a mechanical sense, a sign change simply means a reverse in the direction of turn relative to the output of the second integrator. So now this shaft represents negative of y , or $-y$. Lastly, the final connection is made from this shaft to the input of the first integrator; recall that the input of the first integrator was called \ddot{y} , so that $-y = \ddot{y}$. Note that if we had simply called the original first input y'' then that equation represented would be, $y = -\int \int y'' dx dx$, in which we would differentiate this equation twice with respect to the independent variable. This is equivalent to $\ddot{y} = -y$, which was what we wanted. (See Figure 4.)

Now that the machine has been programmed to solve the equation $\ddot{y} = -y$, the solution is represented by the shaft labeled y . At an operator's discretion, a plot of y against the independent variable can be created by means of an output table. Two different output tables are depicted in the diagram, one is the solution plotted against the independent variable x , and the other is the solution parametrically plotted against its derivative. The former is a sine curve and the latter is a circle, this is due to the fact that the initial conditions were set such that, $\ddot{y}(0) = 0$, and $\dot{y}(0) = 1$. The initial

Figure 4: Simple Harmonic Motion : $\ddot{y} = -y$

conditions are set by the initial derivative distances on each integrator; that is, the highest order derivative corresponds to the first integrator, etc.

The output table is a very simple design. The table rests on a carriage (like the integrator) and is allowed to move linearly in the horizontal direction. Also there is a pen attachment that is mounted on a carriage. It moves in a linear manner as well but perpendicular to the motion of the carriage. As the table and pen move the graph is plotted on paper attached to the carriage (the operation is similar to an Etch-e-Sketch). Since the movements of both pen and table are governed by lead-screw attachments, an operator can attach the appropriate bus shaft to these lead-screw attachments providing a plot of the relationship between two terms related to differential equation.

The input table is similar in construction to the output table, but serves a different purpose. The input table allows an operator to translate a Cartesian plot, provided by an output table, into shaft rotations. This is done by adding a hand crank to the pen attachment; when the table is moved by some variable (time for instance) an operator must turn the crank in order for the pen to maintain consistency with the existing curve. The number of shaft rotations of the crank will represent the curve as a function of time. The rotation of this crank, fed back in the avenue of interconnections by a bus shaft to the appropriate shaft, is prescribed by the differential equation.

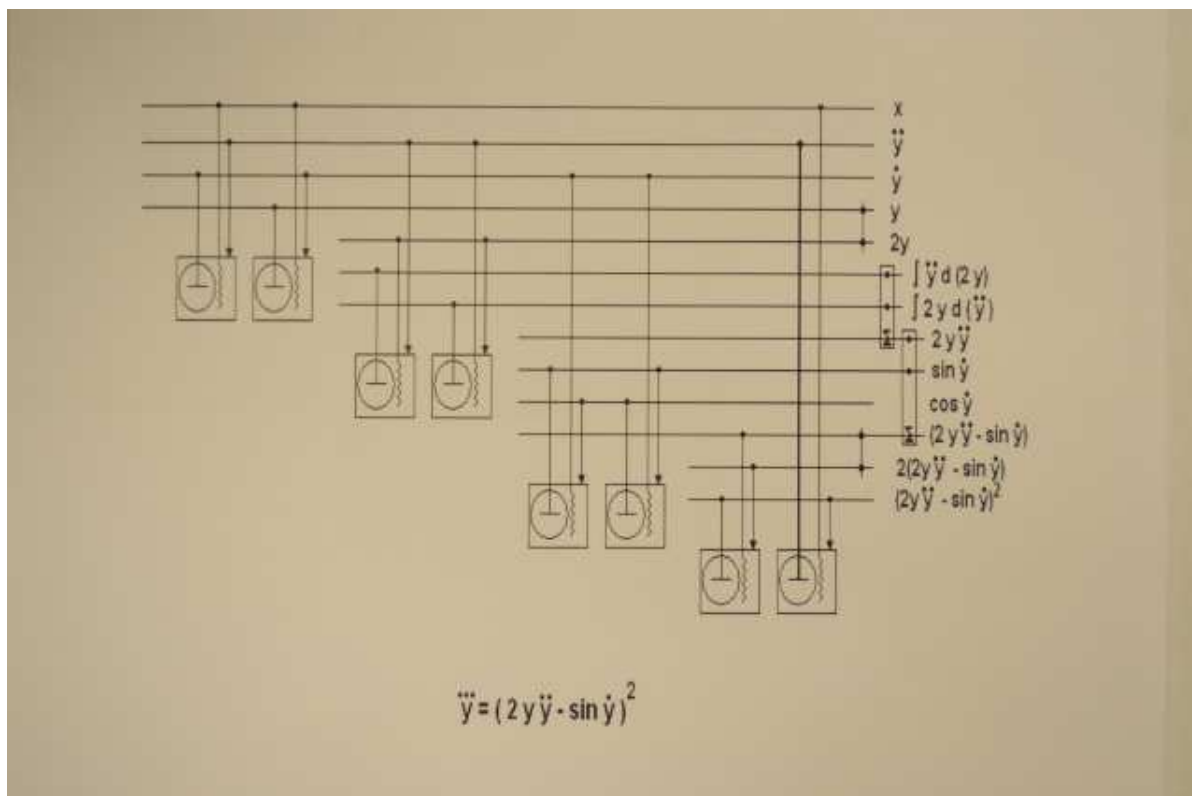

Figure 5: The Schematic for an Interesting Nonlinear Example

The function of an input table is usually to produce some non-homogenous term of the differential equation, so that the addition of this term may be integrated back into the machine to provide the final connection. The schematic for the previous example is that of a linear differential equation with a closed form solution. However, the differential analyzer will solve non-linear equations as well. This is the beauty and power of this magnificent machine. Future projects will be studies of classes of solutions of particular classes of nonlinear equations. The schematic in Figure 5 describes a non-linear D.E. that doesn't have a closed form solution.

5 Some Final Remarks

The goal of the Marshall University Differential Analyzer Project is to provide student and teacher alike with a visual interpretation of abstract mathematical concepts. The differential analyzer has provided an alternative view of integration and differential equations. Additionally, studying the use of mechanical interrelationships to make comparisons of variable interactions is our part of our ongoing research. We also have made plans to provide students in a pilot program the opportunity to learn about the D.A. at the high school level. The differential analyzer was a tool used for many

reasons. It was lost in the midst of a computer revolution and replaced by faster stronger machines. Although the value of time is an issue, so is the value of learning. The differential analyzer has become a teaching tool used to create an environment where critical thinking skills are essential for even the simplest of tasks.

References

- [1] V. Bush and S. H. Caldwell, A new type of differential analyzer, *Journal of the Franklin Institute* **240** (4) (1945), 255 - 326.
- [2] R. Fail, Mini differential analyzer, *Midlands Meccano Guide Gazette* **16** (1993).
- [3] A. Porter and D. Hartree, The construction and operation of a model differential analyzer, *Memoirs and Proceedings of the Manchester Literary Society* **79** (4) (1935), 51-74.
- [4] A. Porter *So Many Hills to Climb*, Beckham Publications Group, 1993.