

9-2010

Pole Arrangements that Introduce Prismatic Joints into the Design Space of Four- and Five-Position Rigid-Body Synthesis

David H. Myszka

University of Dayton, dmyszka1@udayton.edu

Andrew P. Murray

University of Dayton, amurray1@udayton.edu

Follow this and additional works at: https://ecommons.udayton.edu/mee_fac_pub



Part of the [Applied Mechanics Commons](#)

eCommons Citation

Myszka, David H. and Murray, Andrew P., "Pole Arrangements that Introduce Prismatic Joints into the Design Space of Four- and Five-Position Rigid-Body Synthesis" (2010). *Mechanical and Aerospace Engineering Faculty Publications*. 178.

https://ecommons.udayton.edu/mee_fac_pub/178

This Article is brought to you for free and open access by the Department of Mechanical and Aerospace Engineering at eCommons. It has been accepted for inclusion in Mechanical and Aerospace Engineering Faculty Publications by an authorized administrator of eCommons. For more information, please contact frice1@udayton.edu, mschlangen1@udayton.edu.

Pole Arrangements that Introduce Prismatic Joints into the Design Space of Four and Five Position Rigid-Body Synthesis

David H. Myszka* and Andrew P. Murray

*University of Dayton
Dayton, Ohio 45469*

Abstract

The fixed pivots of a planar 4R linkage that can achieve four design positions are constrained to a center-point curve. For five positions, a fixed pivot is limited to the intersection of center-point curves. The curve is a circular cubic and plots can take one of five different forms. The center-point curve can be generated with a compatibility linkage obtained from an opposite pole quadrilateral of the four design positions. This paper identifies four and five position pole configurations where the associated center-point curve(s) includes the line at infinity. With a center-point line at infinity, a PR dyad with line of slide in any direction can be synthesized to achieve the design positions. Further, four and five position pole configurations are identified where the associated circle-point curve(s) includes the line at infinity. With a circle-point that includes a line at infinity, an RP dyad originating anywhere on a center-point curve can be synthesized to achieve the design positions. If the rigid-

*Corresponding author, Tel: +1 937 229 2968, Fax: +1 937 229 4975
Email addresses: dmyszka@udayton.edu (D. Myszka), murray@udayton.edu (A. Murray)

body guidance problem is approximate, small changes to the positions may result in the introduction of a one-parameter family of dyads including a P joint.

Key words: rigid-body guidance, planar synthesis, center-point curves, compatibility linkage

1. Introduction

A center-point curve is the locus of feasible fixed pivot locations for a planar 4R linkage that will guide the coupler through four finitely separated positions. The theory, originally formulated by Burmester [1], is described in numerous classic sources [2, 3, 4] and continues to be an essential element of more recent machine theory textbooks [5, 6, 7]. To guide a coupler through five positions, the fixed pivot is limited to the intersection of the five center-point curves generated by taking all five combinations of four positions [8].

The equation of the center-point curve is

$$\begin{aligned} (C_1x + C_2y)(x^2 + y^2) + C_3x^2 + C_4y^2 + C_5xy \\ + C_6x + C_7y + C_8 = 0, \end{aligned} \tag{1}$$

which is classified as a circular cubic. Keller [9] shows that the constants C_i are not independent and a function of the coordinates of an opposite pole quadrilateral. Thus, the opposite pole quadrilateral dictates the shape of the center-point curve.

Sandor and Erdman [10] present an algebraic formulation for the center-point curve that

is similar in form to a closure equation for a four-bar linkage. Further, they introduce the concept of a “compatibility linkage” as a conceptual linkage whose solution for various crank orientations will generate points on the center-point curve. They show that the curve can be parameterized based on the conceptual crank angle of the compatibility linkage. McCarthy [11] shows that the opposite pole quadrilateral serves as a compatibility linkage and uses its crank angle to parameterize the center-point curve. Murray and McCarthy [12] state that there is a two dimensional set of quadrilaterals that can generate a given center-point curve. Barker [13] classified four-bar mechanisms based on the permissible motions. Schaaf and Lammers [14] applied Barker’s classifications to compatibility linkages to distinguish the geometric form of the associated center-point curve.

Beyer [3] illustrates five possible geometric forms of the center-point curve. Chase et al., [15] observe that the form of the center-point curve is dependent on the motion type of the compatibility linkage. They show that a Grashof compatibility linkage (one where at least one link can make a full revolution) generates a disjointed (bicursal) center-point curve, as shown in Fig. 1a. A non-Grashof compatibility linkage (one where no link is able to make a full revolution) generates a continuous (unicursal) center-point curve, as shown in Fig. 1b. Schaaf and Lammers [14] expand the work of Chase et al., and note that a change point linkage (transition between Grashof and non-Grashof) will generate three less common forms. A double-point form is the transition between a unicursal and bicursal curve where

the branches are joined at a self-intersection, as shown in Fig. 1c. When the compatibility linkage is a change-point and all sides are unequal, a double-point center-point curve will be generated. The circle-degenerate form consists of a circle intersected by a straight line. The hyperbolic-degenerate form is an equilateral hyperbola and a line at infinity. A change-point linkage that has two equal pairs or all equal lengths will generate either a circular-degenerate or a hyperbolic-degenerate center-point curve. Myszka and Murray [16] state that if the configuration of the compatibility linkage is open, a hyperbolic-degenerate will result, as shown in Fig. 1e. If the compatibility linkage is crossed, a circular-degenerate will result, as shown in Fig. 1d.

The study presented in this paper identifies position and pole arrangements that introduces a one parameter family of solutions to rigid-body guidance. Specifically, pole arrangements for four and five position cases are identified that have a center-point at infinity, allowing a PR dyad in any direction to achieve the design positions. Additionally, pole arrangements for four and five position cases that have a circle-point at infinity allow an RP dyad to be selected from anywhere along a center-point curve to achieve the design positions. With the aforementioned restrictions on four and five position guidance, adjusting the positions such that the poles are configured into the special orientations will increase the design space.

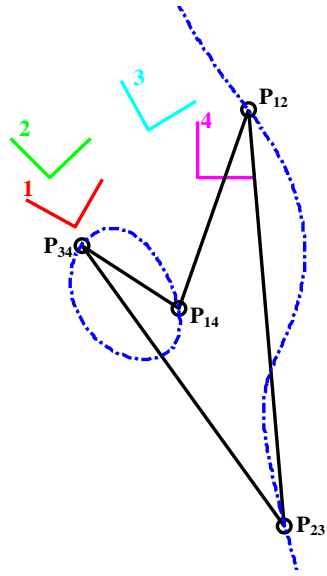

(a) Bicursal.

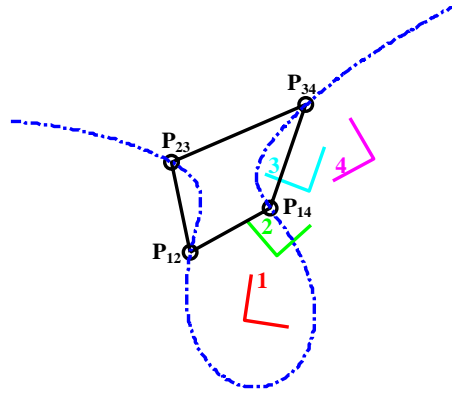

(b) Unicursal.

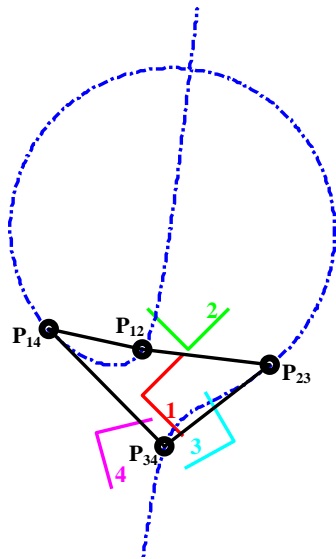

(c) Double-point.

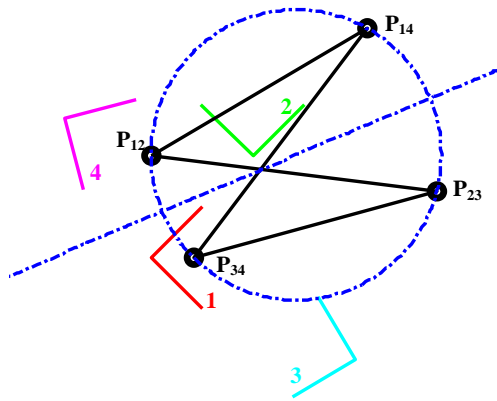

(d) Circle-degenerate.

Figure 1: Five different center-point curve forms.

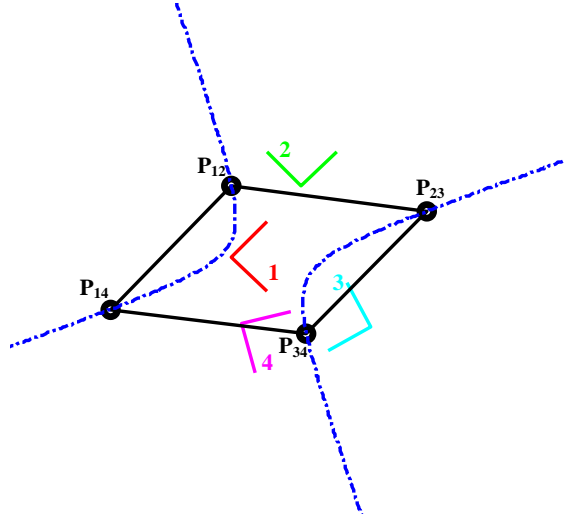

(e) Hyperbola-degenerate.

Figure 1: Five different center-point curve forms (con't).

2. Four Position Cases

2.1. Compatibility Linkage and Center-point Curves

In dealing with precision point synthesis, the location of the i^{th} design position in the fixed frame is specified with a rotation angle θ_i and a translation vector $\mathbf{d}_i = (d_{ix}, d_{iy})^T$. A rotation matrix is calculated as

$$A_i = \begin{bmatrix} \cos \theta_i & -\sin \theta_i \\ \sin \theta_i & \cos \theta_i \end{bmatrix}. \quad (2)$$

Any displacement of a rigid body from position j to position k , and vice versa, can be accomplished by a pure rotation about the displacement pole $\mathbf{P}_{jk} = \mathbf{P}_{kj}$, where

$$\begin{aligned}\mathbf{P}_{jk} &= A_j[A_j - A_k](\mathbf{d}_k - \mathbf{d}_j) + \mathbf{d}_j \\ &= A_k[A_j - A_k](\mathbf{d}_k - \mathbf{d}_j) + \mathbf{d}_k.\end{aligned}\tag{3}$$

Given four specified positions, six displacement poles exist (\mathbf{P}_{12} , \mathbf{P}_{13} , \mathbf{P}_{14} , \mathbf{P}_{23} , \mathbf{P}_{24} and \mathbf{P}_{34}).

An opposite pole quadrilateral is defined by four poles, such that the poles along the diagonal do not share an index. For the four position case, three different opposite pole quadrilaterals can be formed with vertices: $\mathbf{P}_{12}\mathbf{P}_{23}\mathbf{P}_{34}\mathbf{P}_{14}$, $\mathbf{P}_{12}\mathbf{P}_{24}\mathbf{P}_{34}\mathbf{P}_{13}$, and $\mathbf{P}_{13}\mathbf{P}_{23}\mathbf{P}_{34}\mathbf{P}_{14}$. Note that as a distinctive shape is formed with one opposite pole quadrilateral, the others will also form that same shape. Therefore, it is sufficient to focus on a single opposite pole quadrilateral. To that end, the development presented in the remaining sections of the paper will focus on the quadrilateral $\mathbf{P}_{12}\mathbf{P}_{23}\mathbf{P}_{34}\mathbf{P}_{14}$.

2.2. Opposite Pole Quadrilateral forming a Rhombus

Barker [13] identified a linkage having all sides of equal length as a class 6, change point linkage. A shape having all sides with equal lengths and parallel opposite sides is a rhombus. A compatibility linkage taking the form of a rhombus will result in a center-point curve that appears as two intersecting lines, which is a limiting case of the hyperbolic-degenerate form.

As an example of the opposite-pole quadrilateral taking the form of a rhombus, four

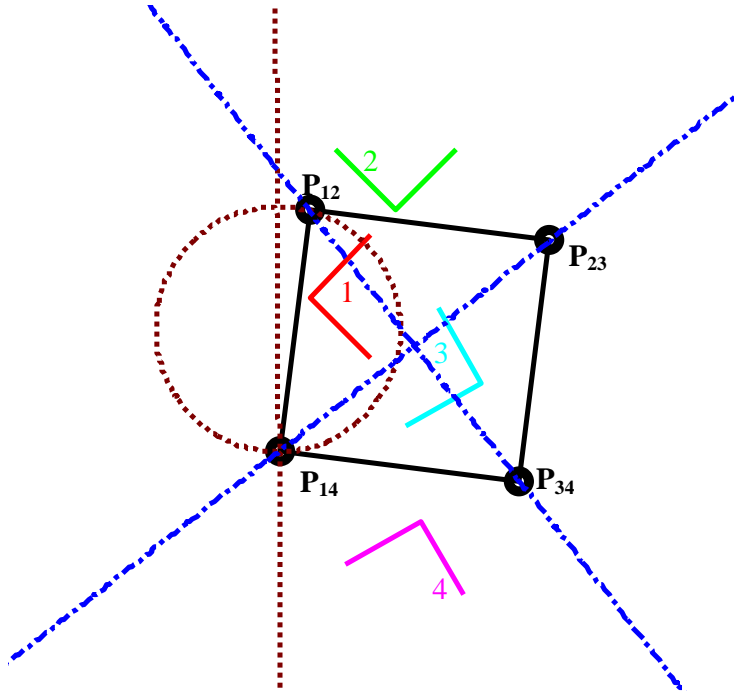

Figure 2: Opposite pole quadrilateral forming a rhombus.

positions are given as $\mathbf{d}_1 = (0, 0)^T$, $\theta_1 = -45^\circ$, $\mathbf{d}_2 = (1, 1)^T$, $\theta_2 = 45^\circ$, $\mathbf{d}_3 = (2, -1)^T$, $\theta_3 = 120^\circ$, $\mathbf{d}_4 = (0.7753, -2.2247)^T$ and $\theta_4 = -120.0^\circ$. The resulting poles and center-point curve are shown in Fig. 2. The opposite pole quadrilateral forms a rhombus and the center-point curve appears as two intersecting lines. Burmester [1] originally recognized that, as the center-point curve degenerates into an equilateral hyperbola, the curve also contains the line at infinity. Also shown in Fig. 2 as the dotted red curve is the circle-point curve associated with the first position, which has a circle-degenerate form.

2.3. *Opposite Pole Quadrilateral forming a Parallelogram*

Barker [13] identified a linkage having two sets of opposite sides having the same length as a class 5, change point linkage. A shape having two pairs of opposite sides that are parallel and the same length is a parallelogram. Burmester [1] originally recognized that as the opposite pole quadrilateral is arranged as a parallelogram, the center-point curve will degenerate into an equilateral hyperbola. As stated in the previous section, the curve includes the line at infinity.

As an example of the opposite-pole quadrilateral taking the form of a parallelogram, four positions are given as $\mathbf{d}_1 = (0, 0)^T$, $\theta_1 = -45^\circ$, $\mathbf{d}_2 = (1, 1)^T$, $\theta_2 = 45^\circ$, $\mathbf{d}_3 = (2, -1)^T$, $\theta_3 = 120^\circ$, $\mathbf{d}_4 = (0.1466, -0.9675)^T$, and $\theta_4 = -75^\circ$. The resulting poles and center-point curve are shown in Fig. 3. As the opposite pole quadrilateral forms a parallelogram, the center-point curve is an equilateral hyperbola. Also shown as the dotted curve is the circle-point curve associated with the first position, which has a circle-degenerate form.

2.4. *Opposite Pole Quadrilateral forming a Folded Rhombus or Crossed Parallelogram*

A folded rhombus is a shape that has four equal length sides, but one diagonal has zero length. A crossed parallelogram has a two sets of equal length sides which are not parallel. A compatibility linkage taking the form of a folded rhombus or crossed parallelogram will result in a circle-degenerate form of a center-point curve. As an example of the crossed parallelogram, four positions are given as $\mathbf{d}_1 = (0, 0)^T$, $\theta_1 = -45^\circ$, $\mathbf{d}_2 = (1, 1)^T$, $\theta_2 = 45^\circ$,

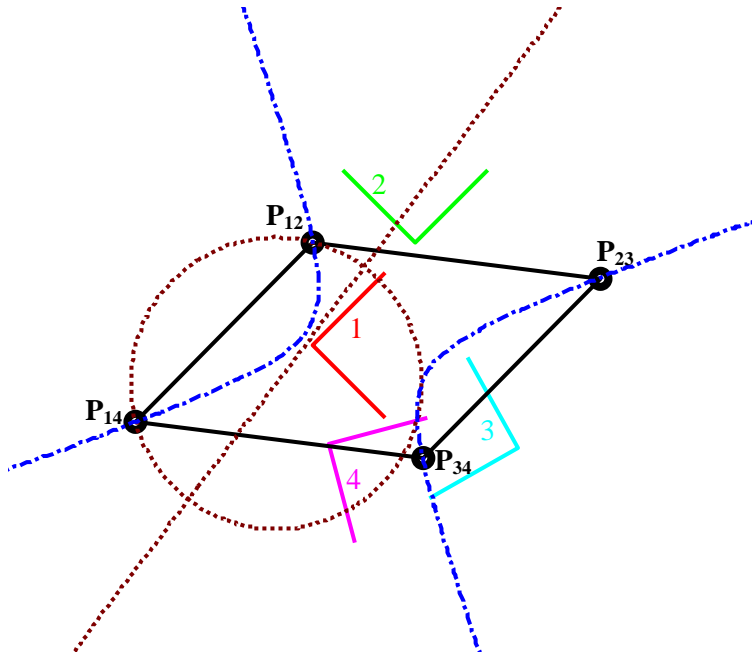

Figure 3: Opposite pole quadrilateral forming an open parallelogram.

$\mathbf{d}_3 = (2, -1)^T$, $\theta_3 = 120^\circ$, $\mathbf{d}_4 = (-0.8395, 1.3653)^T$, and $\theta_4 = -75^\circ$. The resulting poles, opposite pole quadrilateral and center-point curve is shown in Fig. 4. Also shown as the dotted curve is the circle-point curve associated with the first position, which takes the form of equilateral hyperbola. As with the center-point curve, a hyperbolic-degenerate circle-point curve includes the line at infinity.

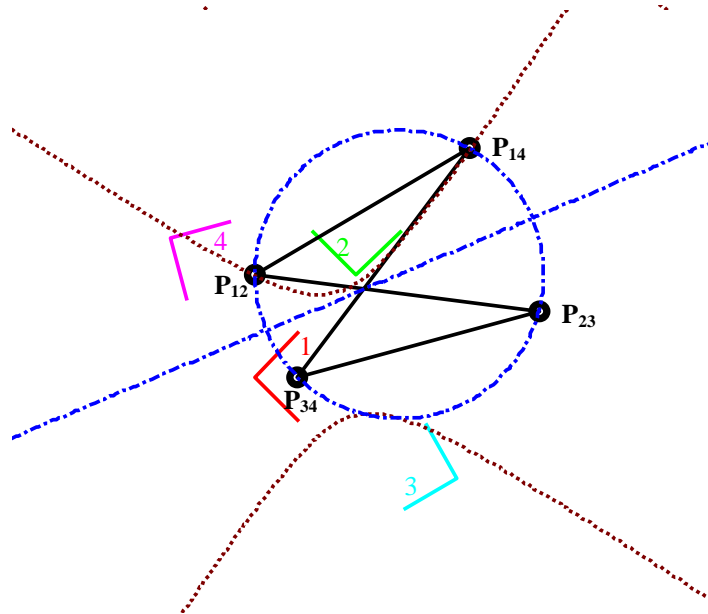

Figure 4: Opposite pole quadrilateral forming a closed parallelogram.

3. Synthesizing PR Dyads

For a general case of four finitely separated positions, one unique prismatic-revolute chain (PR dyad) can be synthesized. A general PR dyad is shown in Fig. 5. The location of the moving pivot relative to the fixed frame is

$$\mathbf{Z}_i = A_i \mathbf{z} + \mathbf{d}_i. \quad (4)$$

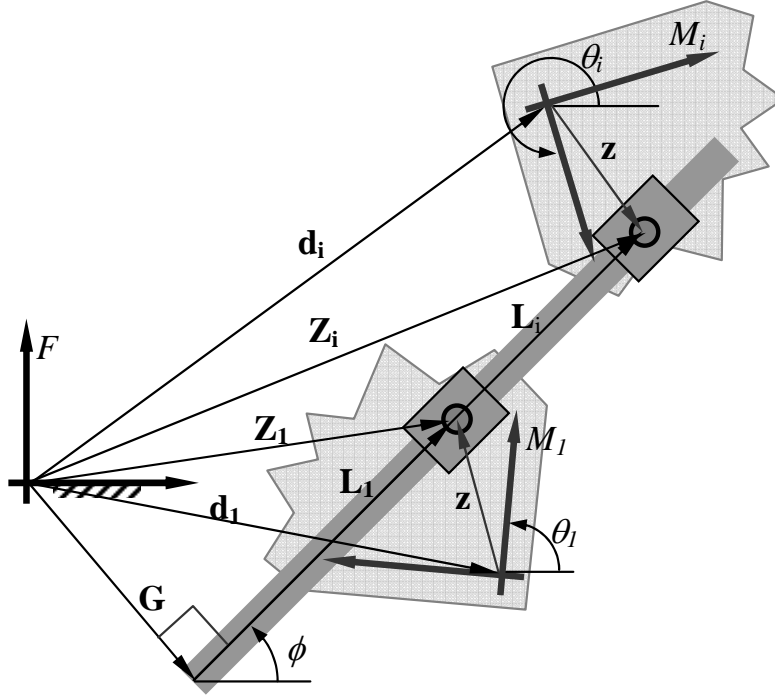

Figure 5: General PR dyad.

Alternatively, the location of the moving pivot relative to the fixed frame as constrained by the slide is

$$\mathbf{Z}_i = \mathbf{G} + L_i \begin{Bmatrix} \cos \phi \\ \sin \phi \end{Bmatrix}, \quad (5)$$

where $L_i = \|\mathbf{L}_i\|$. Combining Eqs. 4 and 5, for two positions i and j , gives

$$(A_j - A_i)\mathbf{z} + (\mathbf{d}_j - \mathbf{d}_i) = L_{ij} \begin{Bmatrix} \cos \phi \\ \sin \phi \end{Bmatrix}, \quad (6)$$

where $L_{ij} = L_i - L_j$.

For four finitely separated positions, three independent versions of Eq. 6 can be expressed

as

$$\begin{bmatrix} [A_4 - A_3] & -\cos \phi & 0 & 0 & \mathbf{d}_4 - \mathbf{d}_3 \\ & -\sin \phi & 0 & 0 & \\ [A_4 - A_2] & 0 & -\cos \phi & 0 & \mathbf{d}_4 - \mathbf{d}_2 \\ & 0 & -\sin \phi & 0 & \\ [A_4 - A_1] & 0 & 0 & -\cos \phi & \mathbf{d}_4 - \mathbf{d}_1 \\ & 0 & 0 & -\sin \phi & \end{bmatrix} \begin{Bmatrix} z_x \\ z_y \\ L_{34} \\ L_{24} \\ L_{14} \\ 1 \end{Bmatrix} = 0. \quad (7)$$

A PR solution exists only if the determinant of the matrix in Eq.7 is zero. For a general set of positions, a single value of ϕ ($0 \leq \phi < \pi$) is possible. The line of slide defined by ϕ will be perpendicular to the asymptote of the center-point curve. As the center-point curve approaches infinity, the highest order terms in Eq. 1 dominate. The equation of the asymptote is

$$C_1x + C_2y = 0, \quad (8)$$

which has a slope

$$m = y/x = -C_1/C_2. \quad (9)$$

As the center-point curve appears as a hyperbola, as in the open parallelogram or rhombus, the center-point curve exhibits two asymptotes and the circle at infinity. For this special

case where the center-point curve includes the line at infinity, the determinant of the matrix in Eq. 7 is zero for any ϕ . This confirms that any five of the six equations can be solved for \mathbf{z} , L_{14} , L_{24} , L_{34} with an arbitrary ϕ . The solution will be consistent with the unused equation. Therefore, for these situations a PR dyad to achieve the four positions can be synthesized with the line of slide in any direction. As an example, PR dyads are synthesized at arbitrary 47° and 152° to achieve the positions illustrated in Fig. 2, and are shown in Figs. 6a and 6a, respectively. The two dyads are joined to form a double-slider linkage to achieve the four target positions and is shown in in Figs. 6c. Although the center-point curve degeneracies are thoroughly discussed in the literature, the authors are not aware of previous examples detailing the arbitrary line of slide for the P in a PR chain.

4. Synthesizing RP Dyads

For a general case of four finitely separated positions, one unique revolute-prismatic chain (RP dyad) can be synthesized. A general RP dyad is shown in Fig. 7. Similar to the PR dyad, the location of the prismatic joint can be represented through alternative vector paths, written relative to the moving reference frame M_i as

$$A_i^T (\mathbf{G} - \mathbf{d}_i) = \mathbf{z} + l_i \begin{Bmatrix} -\sin \psi \\ \cos \psi \end{Bmatrix}. \quad (10)$$

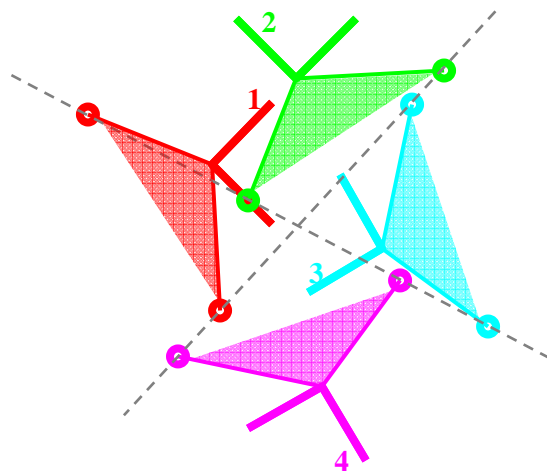
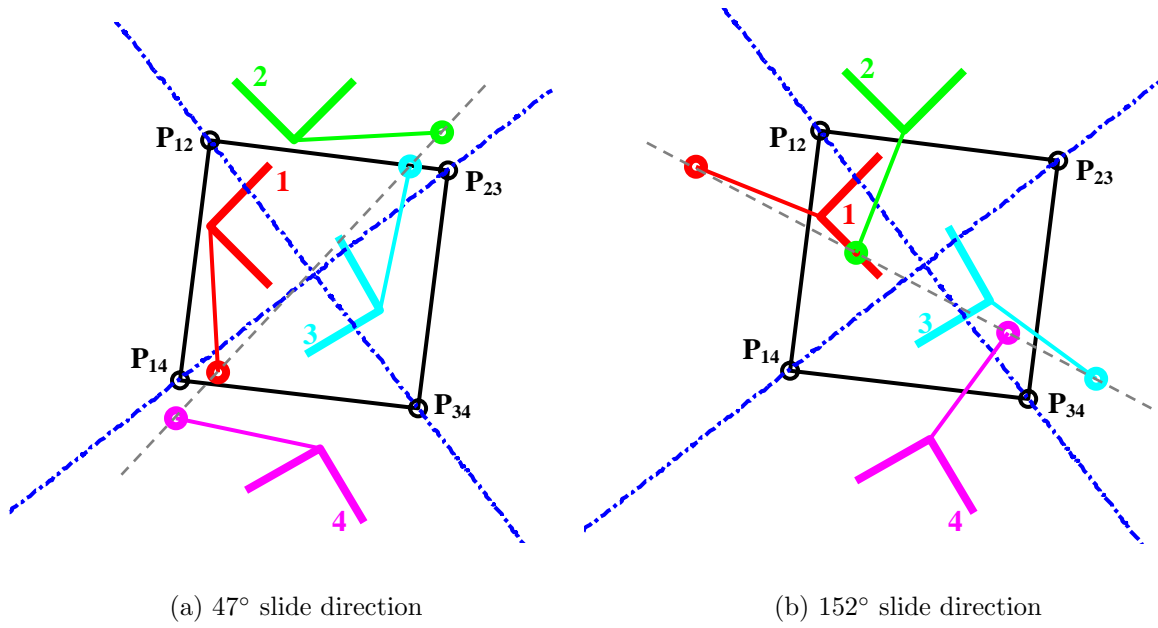

(c) Double-slider mechanism to achieve the four positions

Figure 6: A PR dyad can be oriented in any direction when the center-point curve is a hyperbola.

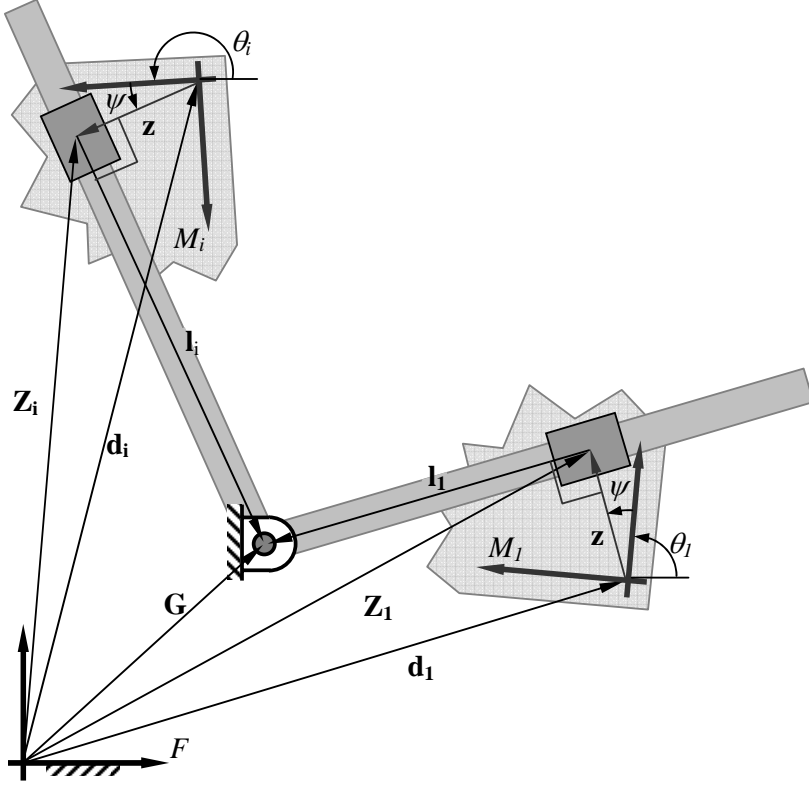

Figure 7: General RP dyad.

Writing Eq. 10 for two positions i and j and subtracting gives

$$(A_i^T - A_j^T) \mathbf{G} + l_{ij} \begin{Bmatrix} \sin \psi \\ -\cos \psi \end{Bmatrix} = (A_i^T \mathbf{d}_i - A_j^T \mathbf{d}_j). \quad (11)$$

where $l_{ij} = |l_i - l_j|$. For the general case of four finitely separated positions, three independent versions of Eq. 11 can be expressed, which allows determination of six parameters: \mathbf{G} , l_{14} , l_{24} , l_{34} , and ϕ .

For four finitely separated positions, three independent versions of Eq. 11 can be expressed

as

$$\begin{bmatrix} [A_4 - A_3]^T & \sin \psi & 0 & 0 & (A_3^T \mathbf{d}_3 - A_4^T \mathbf{d}_4) \\ & -\cos \psi & 0 & 0 & \\ [A_4 - A_2]^T & 0 & \sin \psi & 0 & (A_2^T \mathbf{d}_2 - A_4^T \mathbf{d}_4) \\ & 0 & -\cos \psi & 0 & \\ [A_4 - A_1]^T & 0 & 0 & \sin \psi & (A_1^T \mathbf{d}_1 - A_4^T \mathbf{d}_4) \\ & 0 & 0 & -\cos \psi & \end{bmatrix} \begin{Bmatrix} G_x \\ G_y \\ l_{34} \\ l_{24} \\ l_{14} \\ 1 \end{Bmatrix} = 0. \quad (12)$$

An RP solution exists only if the determinant of the matrix in Eq.12 is zero. For a general set of positions, as in the case of the PR dyad, a single value of ϕ ($0 \leq \phi < \pi$) is possible.

As the circle-point curve appears as a hyperbola, as in the crossed parallelogram or folded rhombus, the circle-point curve exhibits two asymptotes and the line at infinity. For this special case where the circle-point curve includes the line at infinity, the determinant of the matrix in Eq. 12 is zero for any ϕ . This confirms that any five of the six equations can be solved for \mathbf{G} , L_{14} , L_{24} , L_{34} with an arbitrary ϕ . The solution will be consistent with the unused equation. The corresponding fixed pivot \mathbf{G} will always lie along the circular portion of the center-point curve. Therefore, an RP dyad to achieve the special case of four positions can be synthesized for any point along the circular portion of the center-point curve. As an example, two RP dyads are synthesized from arbitrary points on the center-point curve

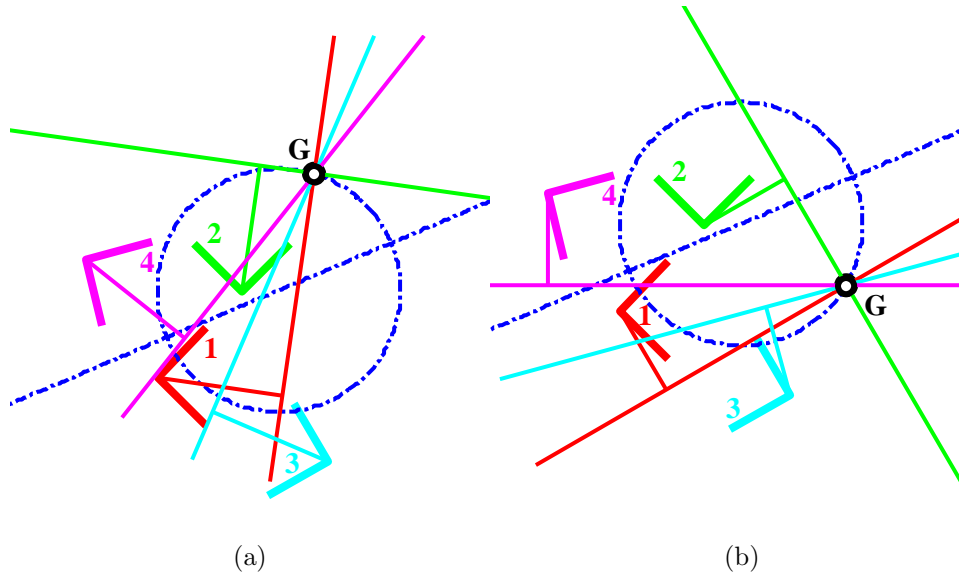

Figure 8: Two RP dyads are synthesized from arbitrary points on the center-point curve.

illustrated in Fig. 4, is shown in Fig. 8.

5. Five Position Cases

For five general design positions, a discrete number of locations (0, 2 or 4) are possible for a fixed pivot of an RR dyad. The fixed pivot locations correspond with the intersection of all five center-point curves generated by taking every four position combination. With five positions, 10 poles exist (\mathbf{P}_{12} , \mathbf{P}_{13} , \mathbf{P}_{14} , \mathbf{P}_{15} , \mathbf{P}_{23} , \mathbf{P}_{24} , \mathbf{P}_{25} , \mathbf{P}_{34} , \mathbf{P}_{35} and \mathbf{P}_{45}). Three center-point curves will intersect at a pole as the two positions that the define the pole are used in the generation of the center-point curves.

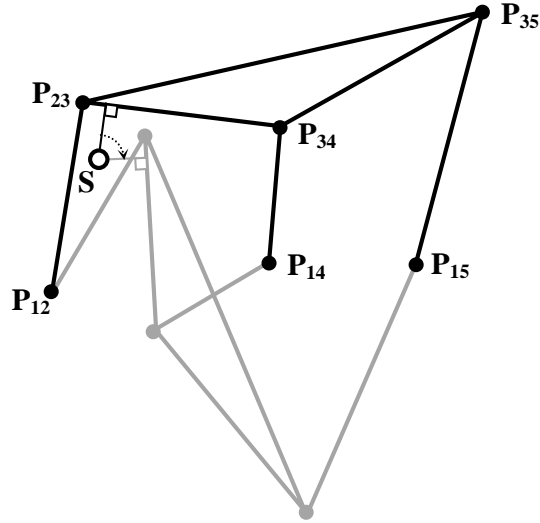

Figure 9: Compatibility structure for five position synthesis.

A compatibility platform can be constructed analogous to the compatibility linkage from P_{12} , P_{14} , P_{15} , P_{23} , P_{34} and P_{35} as shown in Fig. 9. As Murray and McCarthy [17] describe, fixed pivot locations coincide with the displacement poles of the platform P_{23} , P_{34} and P_{35} , for the different assembly configurations of a compatibility platform. One such solution point is shown as S in Fig. 9.

5.1. Case 1: Movable Compatibility Platform

A noteworthy case for the five position guidance problem aligns the poles such that the compatibility platform contains three equal length and parallel cranks. As in the general

case, this compatibility platform can have different assembly configurations revealing fixed pivots for an RR dyad. It is noteworthy in that because of the symmetry the structure is able to move as a triple crank. The motion of the platform is an orbital translation where each point on the platform traces a circle, and the displacement poles form a line at infinity. Like the four position cases where the center-point curve includes a line at infinity, a PR dyad can be synthesized to achieve the five positions with the line of slide in any arbitrary direction.

As an example of a compatibility platform with motion, five positions are given as $\mathbf{d}_1 = (0, 0)^T$, $\theta_1 = -45^\circ$, $\mathbf{d}_2 = (1, 1)^T$, $\theta_2 = 45^\circ$, $\mathbf{d}_3 = (2, -1)^T$, $\theta_3 = 120^\circ$, $\mathbf{d}_4 = (1.4691, -2.6237)^T$, $\theta_4 = 200^\circ$, $\mathbf{d}_5 = (0.1040, -0.8033)^T$, and $\theta_5 = 290^\circ$. This movable compatibility platform and an alternate assembly configuration are shown in Fig. 10a. An RR dyad, synthesized from the displacement pole of the compatibility platform is shown in Fig. 10b. Two PR dyads are synthesized at arbitrary directions of 57° and 162° , and shown in Fig. 10c.

5.2. Case 2: Alternate Configuration of the Movable Compatibility Platform

A second interesting case is revealed if a movable compatibility platform, as in Fig. 10b, is placed in an alternate configuration. An alternate configuration is shown in gray in Fig. 10a. As described earlier, fixed pivot locations for the five positions correspond to the pole of the compatibility platform with another configuration. In this case, the other configuration is able to move, and the displacement pole becomes a curve. Thus a center-point curve for five

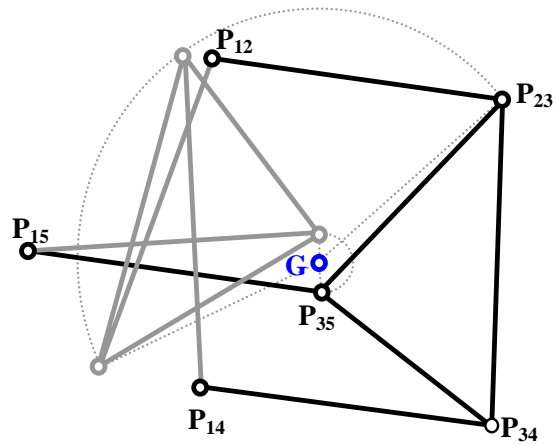

(a)

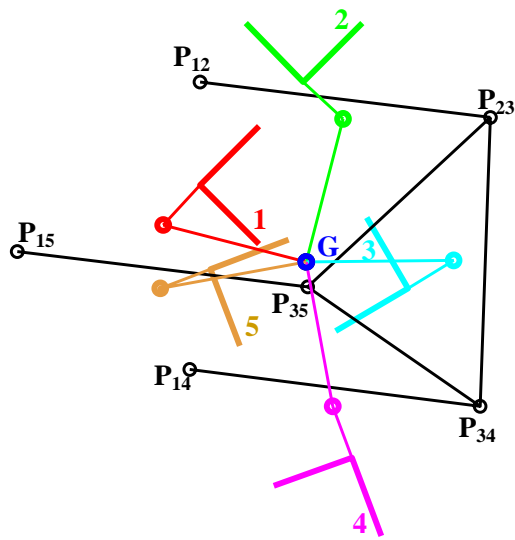

(b)

Figure 10: Five positions with a compatibility structure that has motion.

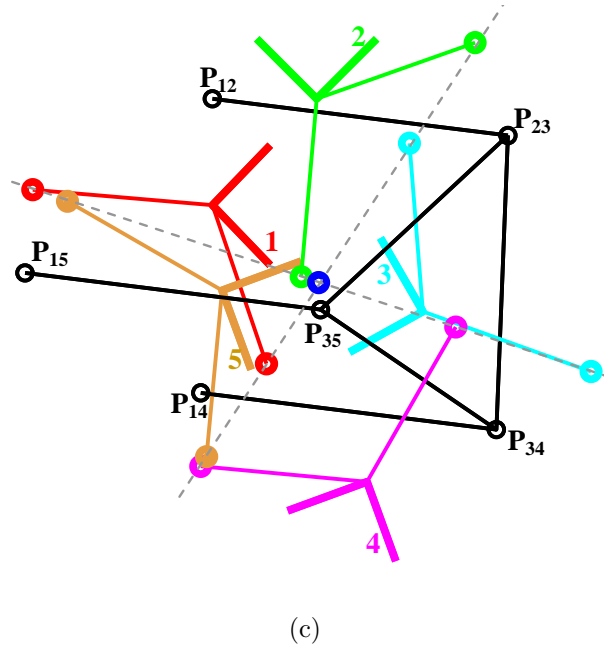

Figure 10: Five positions with a compatibility structure that has motion (con't).

positions is obtained. However, the corresponding circle-point is at infinity. As with the four position case with a circle-point at infinity, an RP dyad can be constructed from any point on the center-point curve that achieves the five design positions.

Pole locations that place the compatibility platform of Fig. 10b into an alternate configuration are shown in Fig. 11a. Positions consistent with this set of poles are $\mathbf{d}_1 = (0, 0)^T$, $\theta_1 = 0^\circ$, $\mathbf{d}_2 = (0.9914, 0.8692)^T$, $\theta_2 = 82.5^\circ$, $\mathbf{d}_3 = (-3.2602, 0.7422)^T$, $\theta_3 = -195.0^\circ$, $\mathbf{d}_4 = (1.6268, -1.3416)^T$, $\theta_4 = -72.5^\circ$, $\mathbf{d}_5 = (-3.2472, -1.7717)^T$, and $\theta_5 = -162.5^\circ$. The center-point curve for these five positions is shown as blue in Fig. 11a. Two RP dyads are

synthesized from arbitrary points on the center-point curve, and shown in Fig. 11b and c.

The prescription for pole locations that generate the alternative compatibility platform is shown in Fig 12. The three poles \mathbf{P}_{23} , \mathbf{P}_{34} , and \mathbf{P}_{35} define a circle. An arbitrary distance l can be used from \mathbf{P}_{23} to place \mathbf{P}_{12} on the circle. Then, using the same length l , \mathbf{P}_{14} and \mathbf{P}_{15} are placed on the circle in the same rotational direction as \mathbf{P}_{12} . With this arrangement of poles, the design space for five positions includes an infinite number of RP dyads to solve the five-position rigid-body guidance.

6. Example

A rigid guidance design task has the requirements shown in the left portion of Table 1. The task positions, poles, and the five center-point curves are shown in Fig.13. The five center-point curves all intersect at two points, shown as solid markers labeled \mathbf{G}_1 and \mathbf{G}_2 in Fig.13). These are the only two locations that a fixed pivot of an RR chain can be synthesized to achieve the five positions. As the positions are shifted as indicated in the right portion of Table 1, the poles become arranged into a Case 2 compatibility platform, which exhibits a center-point curve. The shifted position arrangement along with the platform is shown in Fig. 14.

The center of the center-point circle is a feasible fixed pivot for an RR dyad. Any arbitrary point along the center-point circle can be selected as the fixed pivot of a RP dyad. Joining

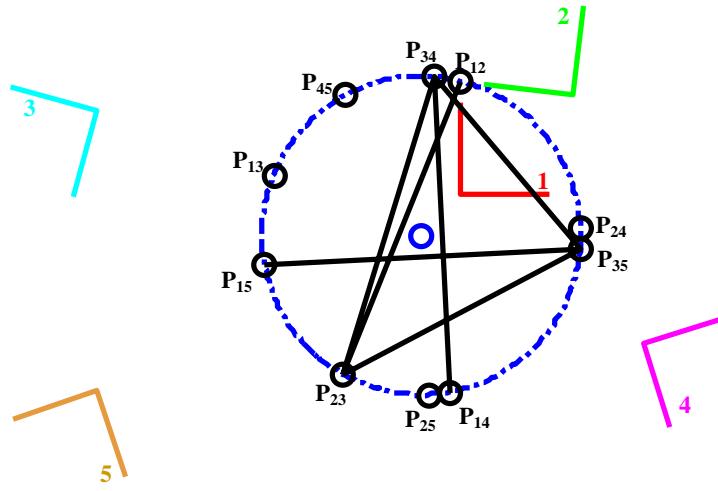

(a)

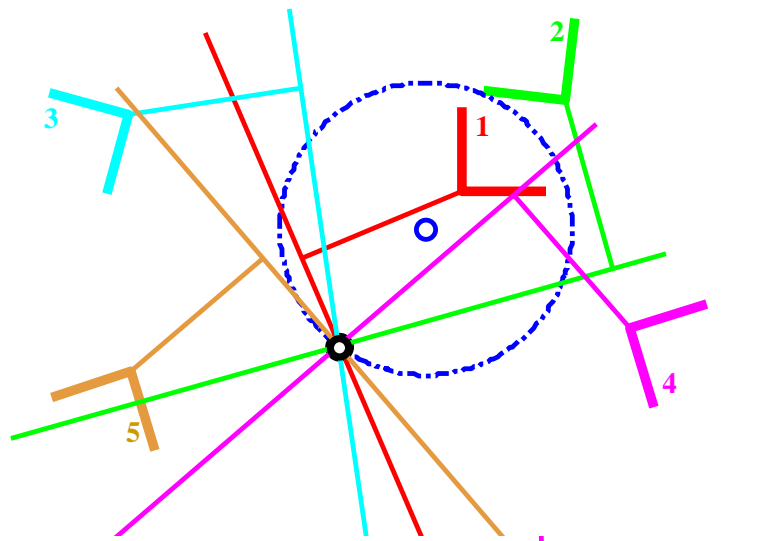

(b)

Figure 11: Center-point curve for five design positions.

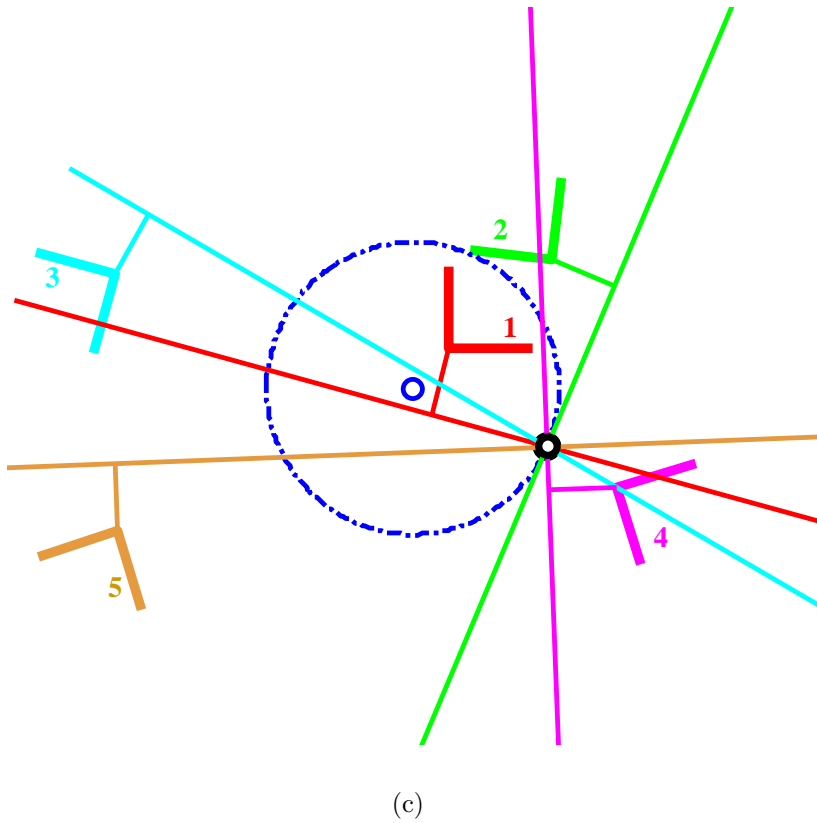

Figure 11: Center-point curve for five design positions (con't).

the two dyads, an RRPR linkage can be synthesized to achieve the five shifted positions is shown in Fig. 15.

7. Conclusions

The study presented in this paper identifies four and five position pole configurations where the associated center-point curve(s) includes the line at infinity. With a center-point line at infinity, a PR dyad with line of slide in any direction can be synthesized to achieve

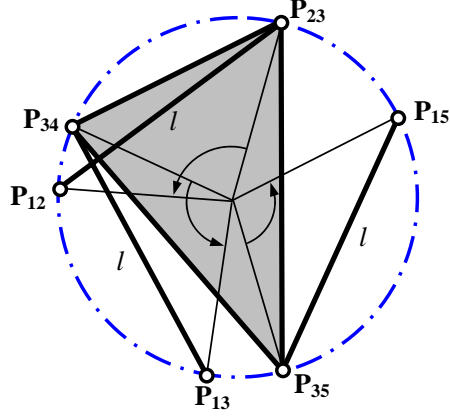

Figure 12: Pole locations that generate a center-point curve for five design positions.

Table 1: Target Positions for Example.

i	Target Positions			Shifted Positions		
	θ_i	d_{ix}	d_{iy}	θ_i	d_{ix}	d_{iy}
1	40°	-0.5	2.5	41.8°	-0.348	2.461
2	30°	0.5	2.5	29.9°	0.479	2.301
3	-10°	1.5	1.5	-8.9°	1.706	1.766
4	-40°	2.8	2.5	-41.8°	2.768	2.386
5	-75°	5.5	2.5	-76.5°	5.719	2.389

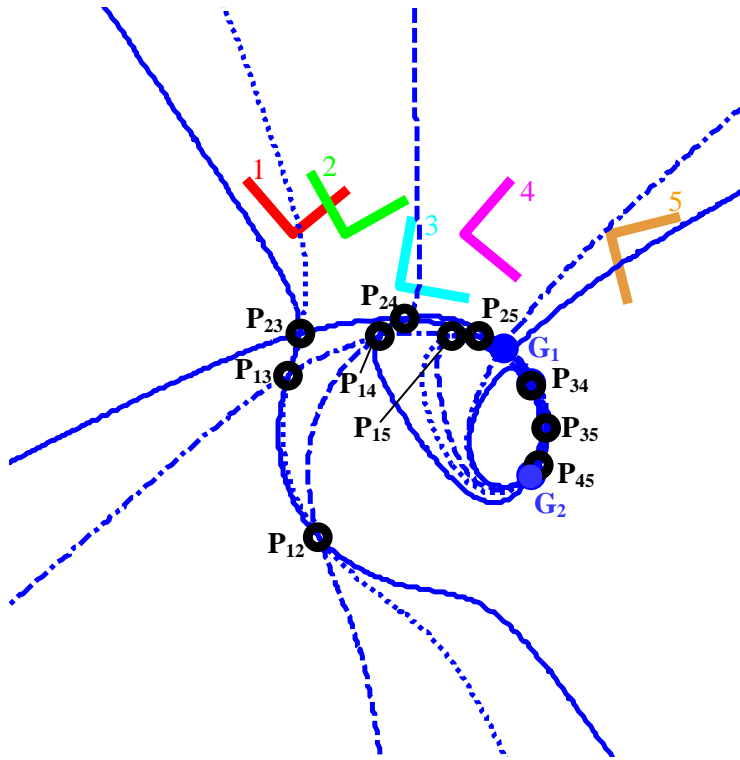

Figure 13: Two fixed pivot locations correspond with the five target positions of Table 1.

the design positions. Further, four and five position pole configurations are identified where the associated circle-point curve(s) includes the line at infinity. With a circle-point that includes a line at infinity, an RP dyad originating anywhere on a center-point curve can be synthesized to achieve the design positions. By adjusting the positions in four and five position guidance problems such that the poles are configured into the special orientations, the design space will significantly increase.

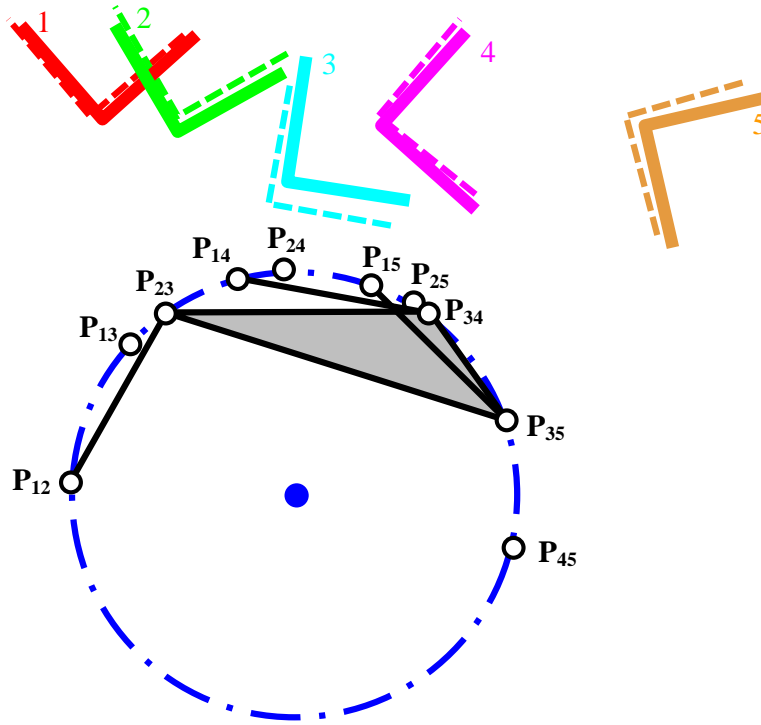

Figure 14: Shifted target positions to reorient the poles into a Case 2 compatibility platform.

References

- [1] Burmester, L., *Lehrbuch der Kinematic*. Verlag Von Arthur Felix, Leipzig, Germany, 1886.
- [2] Hall, A. S., *Kinematics and Linkage Design*. Prentice-Hall, Englewood Cliffs, New Jersey, 1961.

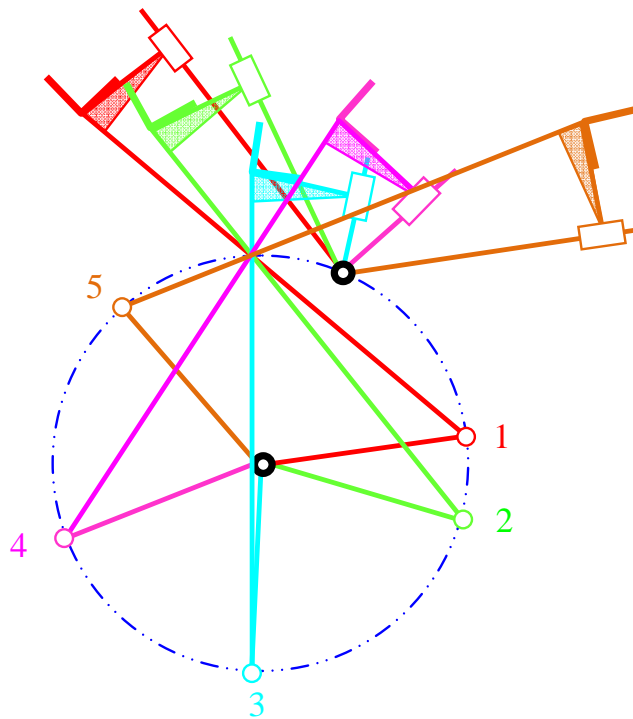

Figure 15: An arbitrary RRPR linkage to nearly achieve the five task positions.

- [3] Beyer, R., *Kinematic Synthesis of Mechanisms* translated by H. Kuenzel, McGraw-Hill, New York, 1963.
- [4] Bottema, O., Roth, B., *Theoretical Kinematics*. North-Holland Publishing Company, New York, 1979.
- [5] Erdman, A., Sandor, G., Kota, S., *Mechanism Design: Analysis and Synthesis*. Vol. 1,

- 4/e, Prentice-Hall, Englewood Cliffs, New Jersey, 2001.
- [6] Norton, R., *Kinematics and Dynamics of Machinery.*, 4/e., McGraw Hill Book Company, New York, 2008.
- [7] Waldron, K., Kinzel, G., *Kinematics, Dynamics and Design of Machinery.*, 2/e., John Wiley & Sons Inc., New Jersey, 2004.
- [8] McCarthy, J. M., *Geometric Design of Linkages.*, Springer-Verlag, New York, 2000.
- [9] Keller, R. E., Sketching Rules for the Curves of Burmester Mechanism Synthesis, *Journal of Engineering for Industry* 87(5) (1965) 155-160.
- [10] Sandor, G. N., Erdman, A. G., *Advanced Mechanism Design: Analysis and Synthesis, Vol. 2.* Prentice-Hall, Englewood Cliffs, New Jersey, 1984.
- [11] McCarthy, J. M., The Opposite Pole Quadrilateral as a Compatibility Linkage for Parameterizing the Center-point Curve, *Journal of Mechanical Design* 115(2) (1993) 332-336.
- [12] Murray, A. P., McCarthy, J. M., Center-point Curves Through Six Arbitrary Points, *Journal of Mechanical Design* 119(1) (1997) 33-39.
- [13] Barker, C., A Complete Classification of Planar Four-Bar Linkages, *Machine and Mechanism Theory* 20(6) (1985) 535-554.

- [14] Schaaf, J., Lammers, J., Geometric Characteristics of the Center-point Curve Based on the Kinematics of the Compatibility Linkage, *Proc. of the ASME Design Engineering Technical Conference*, 1992.
- [15] Chase, T. R., Erdman, A. G., Riley, D. R., Improved Center-point Curve Generation Techniques for Four-Precision Position synthesis Using the Complex Number Approach. *Journal of Mechanical Design* 107(3) (1985) 370-376.
- [16] Myszka, D. H., Murray, A. P., Identifying Sets of Four and Five Positions that Generate Distinctive Center-Point Curves. *Proc. of the ASME Design Engineering Technical Conference*, 2009.
- [17] Murray, A. P., McCarthy, J. M., Determining Burmester Points from the Analysis of a Planar Platform, *Journal of Mechanical Design* 117(2A) (1995) 303-307.